

Product: KLUDI SCOPE single lever sink mixer DN 10

Ref.: 339330575

Product description

single lever sink mixer DN 10
 solid lever
 single hole mounted
 flow class A
 Cache aerator M 16,5 x l
 ceramic cartridge with hot water safety device
 swivelling (360°) spout
 rapid installation set
 flexible high pressure supply tubes G 3/8
 noise group I, P-IX 19449/10

Finishes:
 05 chrome

Product picture



Advertisement

- * KLUDI GmbH & Co KG KLUDI SCOPE single lever sink mixer DN 10 item no. 33933..75
- ** ceramic cartridge with hot water safety device Ø 35 mm, DIN EN 817
- *** chrome plated brass, DIN 50930-6

single lever sink mixer, manufacturer KLUDI GmbH & Co KG KLUDI SCOPE single lever sink mixer item no. 33933..75, DN 10, surface: 05 = chrome plated brass, type: single lever sink mixer DN 10, swivel (range 360°) spout, solid lever, lever projection 92 mm, Cache aerator M 16,5 x l, noise level DIN 4109 group I, report no. P-IX 19449/10, flow class A (max. 0,25 l/s), nozzle projection 200 mm, rapid installation set, flexible high pressure supply tubes 3/8 inch with metal body with DVGW / KIWA / WRAS / CSTB length 350 mm, ceramic cartridge with hot water safety device Ø 35 mm, nozzle height 106/138 mm, overall length 122/152 mm, for pressure type water heater, for continuous line heater, PN 10,

Dimensional drawing

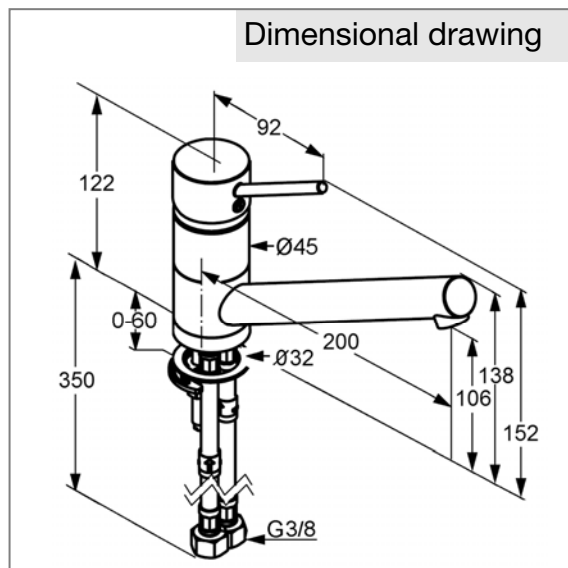

Flow rate diagram

